



PRODUCT INFORMATION

CATALYZER™ 2K 10:1 RATIO Pump

The C.A. Technologies CATALYZER™ is an Air Assist Airless 2 component formulator. Catalyst and base material are pumped into a mixing chamber at 10 : 1 ratio and dispensed at air assist airless pressures for spray applications. The MIX GUARD™ is a unique feature of the CATALYZER™ which senses an “off ratio” condition in the mix chamber and shuts the unit off preventing under or over catalyzed material from being sprayed.



Training videos are available at:
<http://www.spraycat.com/trainingvideos.html>

PATENTS PENDING

IMPORTANT! READ THE HAZARD WARNING INFORMATION

AIR ASSIST AIRLESS OPERATES WITH FLUID PRESSURES UP TO 1500 PSI AND CAN CAUSE SERIOUS INJURY IF IMPROPERLY USED. EVERYONE USING THIS EQUIPMENT MUST READ AND FULLY UNDERSTAND THE SAFETY WARNINGS.

C.A. Technologies
337 S. Arthur Ave.
Louisville, CO 80027
www.spraycat.com

888 820 4498
303 438 5707
FAX 303 438 5708

CATALYZER™ 2 COMPONENT SPRAY SYSTEM

START UP - PRIMING - SHUT DOWN - INSTRUCTION

INITIAL START UP (figure 1)

1. Turn pump pressure regulator completely off (counterclockwise) and close the air inlet ball valve.
2. Attach the main air supply hose to the air inlet ball valve on the pump fluid pressure regulator.
3. Attach fluid hose (YELLOW HOSE) to the quad valve outlet and gun fluid inlet. (figure 2)
4. Attach gun air hose (RED HOSE) to ball valve at gun pressure regulator and to air inlet on gun. Ball valve should be closed and regulator backed off. (figure 3)
5. Add throat seal lubricant (91-36) to both solvent cups.

INSURE THAT ALL CONNECTIONS ARE TIGHT

PRIMING PROCEDURE

1. Pour catalyst into plastic catalyst tank on back of unit.
2. Place base material siphon hose into base material container.
3. Close both the outlet to the fluid hose ball valve and the pressure relief ball valve. (figure 2)
4. Raise both material bypass levers to the vertical (up) position. (figure 2) This allows both materials to circulate back to their respective containers during priming.
5. Turn MIX GUARD™ control knob to the OFF position. (figure 3)
6. Screw in the base material and catalyst port closure knobs. (figure 2)
7. Open air inlet ball valve and rotate regulator knob clockwise slowly increasing pressure until pumps begin to stroke. (Approx. 15 to 20 psi)
8. Allow pumps to operate slowly until all the air is purged from both base material and catalyst pumps.
 - a. Watch the submerged end of the base material return line; when bubbles quit forming, the base pump is primed.
 - b. Watch the return line to the catalyst tank; bubbles will be slowly progressing toward the tank. To speed up this process, move the catalyst bypass lever (red knob) to the down position for about 2 seconds then back up. More bubbles may appear; repeat this until no more new bubbles form in the return tube, the catalyst pump will be primed.
9. Screw out the base material and catalyst port closure knobs. (figure 2)
10. Move both bypass levers **at the same time** to the down (horizontal) position.
11. Increase pump regulator pressure to 40 psi.
12. Hold a waste container under the pressure relief valve (figure 2). Slowly open the valve and allow a small amount of material to flow. This allows pressure in the mix chamber to equalize and assures that no off ratio material is allowed to enter the fluid hose.
13. Open mixed material ball valve and trigger gun a few times to confirm there is no off ratio material.
14. Rotate the MIX GUARD™ control knob to the ON position. The knob should turn easily, if it does not, pressure has not yet equalized in the mix chamber. Repeat steps 7 thru 10 until the knob can be easily turned to the on position.
15. Open the ball valve at the gun pressure regulator. Increase the atomizing air pressure to the gun until the spray pattern is even and no longer has tails.

NOTE: For HVLP compliance, maximum pressure setting on gun regulator is 15 to 18 psi .
Pump pressure may be increased to eliminate tails in pattern.

CAUTION: TO AVOID MATERIAL SPLASHING, ALWAYS REDUCE PUMP PRESSURE TO ZERO BEFORE RAISING LEVERS TO THE UP POSITION.

MIX GUARD™ OPERATION

During operation, if the pressure in the mix chamber becomes unbalanced the MIX GUARD™ knob will move up approx. 1/4" and shut the unit off . This indicates the unit has gone off ratio.

1. **Immediately close the ball valve to the fluid hose to prevent off ratio material from entering the fluid hose.**
2. Check catalyst liquid level, refill if necessary.
3. Check base material liquid level refill if necessary.
4. Close the air inlet ball valve, reduce the pump pressure regulator to approx. 20 psi.
5. Repeat the pump priming procedure starting with step 4. **NOTE: The MIX GUARD™ control knob will need to be pushed down to reset before step 5 can be done.**

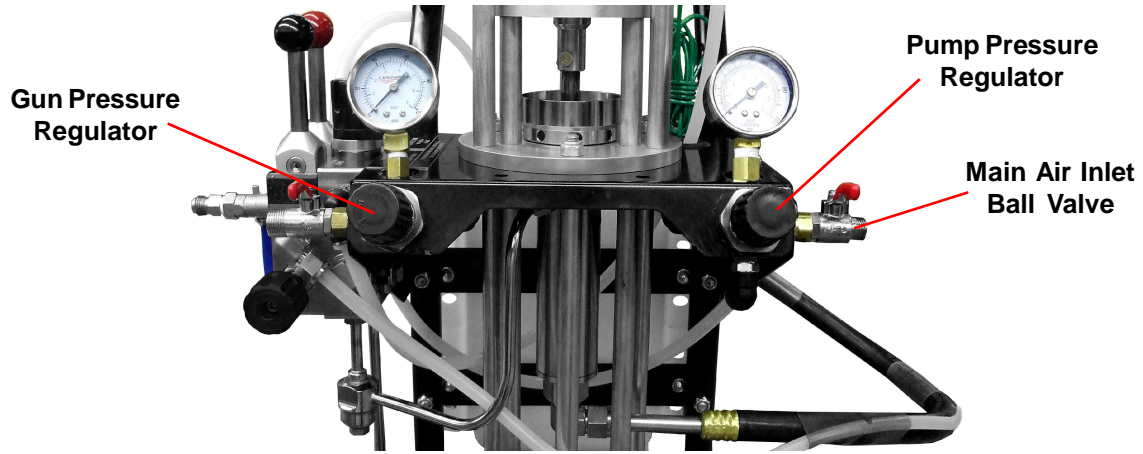

figure 1

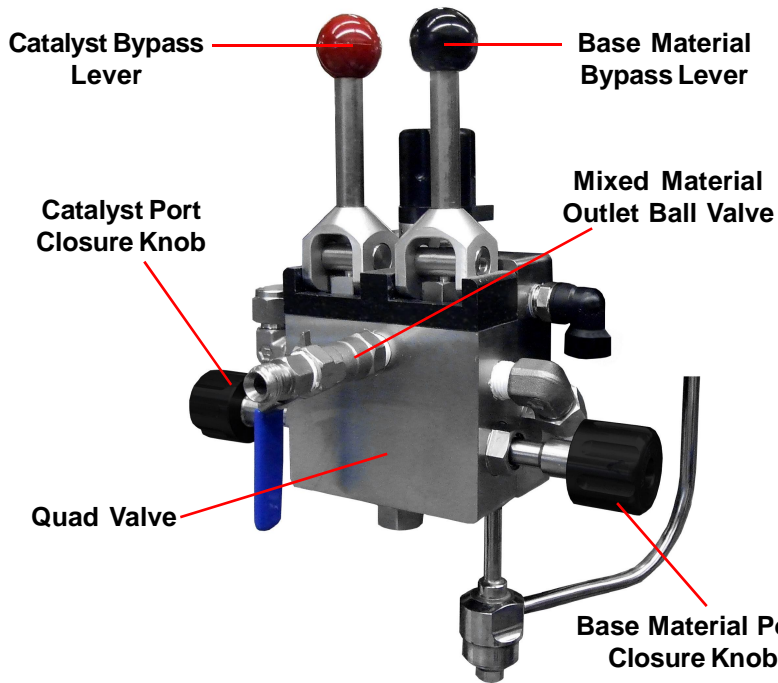

figure 2

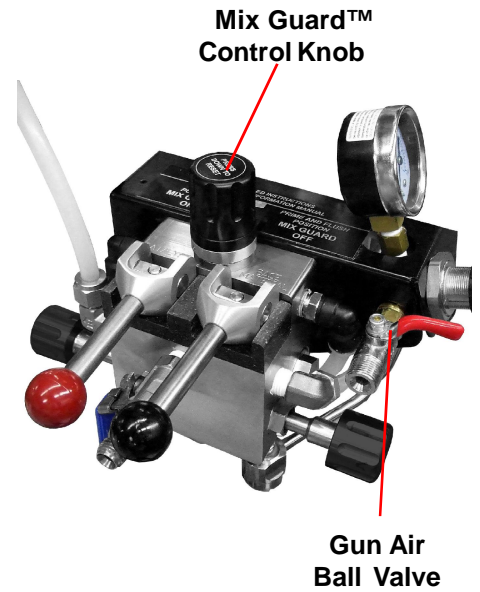

figure 3

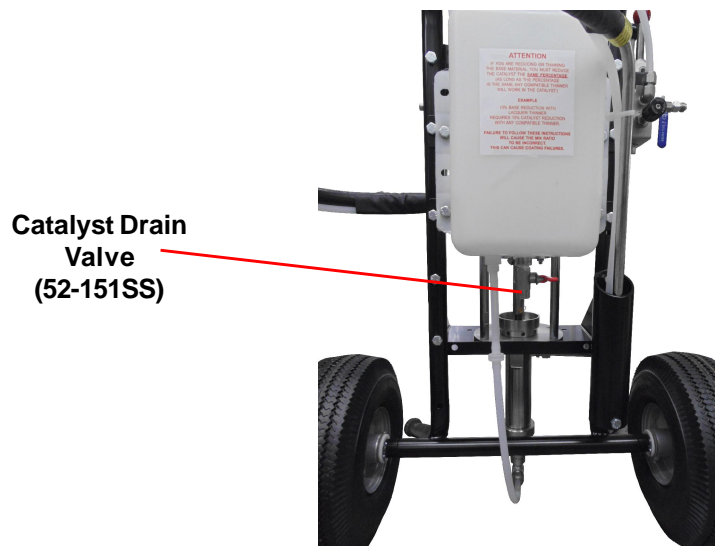

figure 4

CATALYZER™ 2 COMPONENT SPRAY SYSTEM

SHUT DOWN

IMPORTANT: All mixed (catalyzed) material must be flushed from the quad valve, hose, and gun if pump will not be in use for longer than the pot life of the material being sprayed.

1. Reduce pressure to zero on both fluid pressure and air atomizing regulators. Close the air inlet ball valve.
2. Raise both red and black levers on quad valve to up position.
3. Rotate MIX GUARD™ control knob to OFF (prime and flush) position.
4. Lift siphon hose above the level of the base material. Open air inlet ball valve, increase pump pressure until pump strokes slowly (15 to 20 psi) and allow pump to run until all base material has been reclaimed back to the container.
5. Remove siphon tube from base material and put in solvent container. Allow solvent to circulate.
6. Remove air cap and tip from gun and place in clean solvent.
7. Screw in the catalyst port closure knob. (figure 2)
8. Lower black lever on quad valve. Pull trigger on gun to flush out catalyzed material from quad valve, hose and gun into waist container. Move gun to solvent container and circulate. Place waste container under pressure relief valve under quad valve, open ball valve and allow a small amount of solvent to flow. Close ball valve.
9. It is safe to leave the remaining catalyst in the catalyst tank for short term shut down. For longer term shut down or storage, catalyst can be drained using the ball valve under the tank. Add clean solvent to the tank, raise the red lever and allow the pumps to stroke slowly circulating the solvent.
10. Reduce pressure to zero on both fluid pressure and air atomizing regulators. Close the air inlet ball valve. Raise the black lever to the up position. It is safe and recommended to leave a compatible solvent in the base material pump when not in use.
11. Screw out the catalyst port closure knob. (figure 2)

DAILY START UP

Place siphon hose into base material container. Follow **priming** instructions from step 3. Before returning the air cap and tip to the gun, purge out cleaning solvent from fluid line after step 12 (approx. two ounces). Continue with step 13.

Please check and clean the filters regularly on both the base material and catalyst fluid section outlet tube assemblies.

**Base Material Fluid
Section Filter**
(Filter P/N 74-575)

**Catalyst Fluid
Section Filter**
(Filter P/N 74-575)

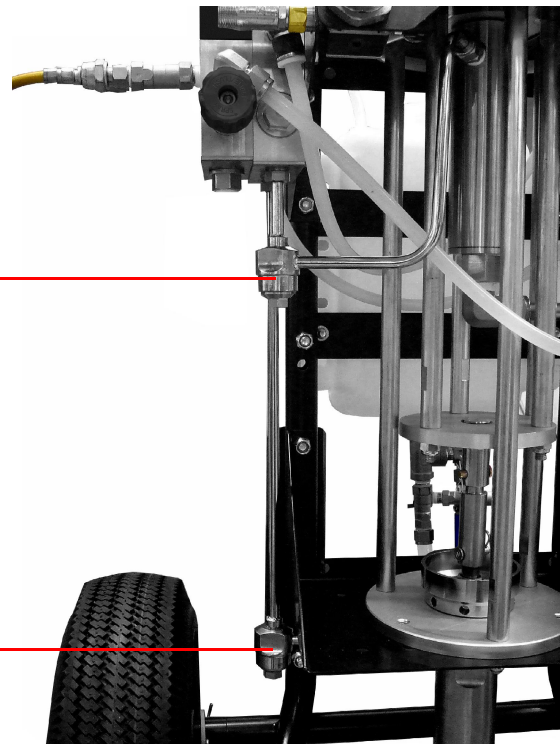

CATALYZER™ 2 COMPONENT SPRAY SYSTEM

CATALYZER TROUBLE SHOOTING PROCEDURE

Prepare Pump for Tests:

- 1) Add fluid to catalyst tank, at least 2" fluid level depth.
- 2) Make sure you have fluid in base side.
- 3) Make sure mix guard knob is in off position.
- 4) Close material outlet ball valve and pressure relief ball valve.

Prime Catalyst and Base Fluid Section:

- 1) Connect pump to air supply and open fluid air regulator to show 10 PSI to 20 PSI run pump and prime catalyst fluid section, raise and lower catalyst bypass lever until all air bubbles are purged.
Check base material to insure all air is purged from base fluid section, base fluid is circulating with no air bubbles.

Pump Testing Procedure:

Items are listed alphabetically. If procedure (A) eliminates the problem, move to the next numerical test step procedure to continue.

- 1) Close both base and catalyst port closure knobs.
- 2) Set fluid air regulator to 10 PSI, lower both base and catalyst bypass valves and raise fluid air regulator to 40 PSI, open pressure relief valve, check for any material dripping from relief valve.
If material is dripping from the relief valve check the following:
 - A) Port closure knobs are not closed. Close and tighten port closure knobs.
Close fluid air regulator ball valve, raise catalyst and base bypass levers to relieve pressure.
- 3) Set fluid pressure regulator to 10 PSI, lower catalyst bypass lever, check to be sure the catalyst fluid section stalls in both up-stroke and down-stroke. Minimal pump movement is normal but pump should not continue to run. If pump continues to run the following items need to be checked:
 - A) Fluid regulator is set above 10 PSI. Set regulator at 10 PSI.
 - A1) Check catalyst return tube, if material continues to drip the catalyst check valve needs cleaning.
 - A2) Catalyst fluid section ball check needs to be cleaned.
 - A3) Check for leaks around the upper seal, tighten if necessary.
 - A4) Catalyst fluid section seals are worn. Replace seals.

● ***Close fluid regulator ball valve and raise catalyst relief lever to relieve pressure.***

- 4) Set fluid air regulator to 20 PSI, lower base material bypass lever and increase pressure to 40 PSI check base fluid section stalls on both up and down stroke. If base pump does not stall check following items:
 - A) Check base return tube, if material continues to drip the base material check valve needs cleaning.
 - A1) Upper or lower ball needs to be cleaned in the base fluid section.
 - A2) Fluid section seals worn. Replace seals.
 - A3) Siphon hose is loose on the pump fluid inlet. Tighten siphon hose nut.

● ***Close fluid air regulator ball valve and raise base bypass lever to relieve pressure.***

Operational Pump Test Procedure:

- 1) Open both catalyst and base port closure knobs.
- 2) Open fluid air regulator and raise pressure to 20 PSI, lower both catalyst and base bypass levers, raise fluid pressure regulator to 40 PSI, place waste container under pressure relief valve and open valve and drain small amount of material into waste container. (Equalizes pressure in quad valve)
- 3) Open mixed material outlet to gun, trigger gun and hold open for second or two insuring mixed material at gun.
- 4) Turn mix guard to on position, mix guard should remain in down position, pull trigger on and off on gun and check that the mix guard knob stays down.
If mix guard raises to up position, check the following:
 - A) Prime the pump per procedure and make sure no air bubbles present in base or catalyst lines.
 - A1) Make sure base and catalyst material containers have material in them.

● ***Leave pump pressurized for next test procedure***

Operational Test Mix Guard :

- 1) Raise catalyst bypass lever, mix guard should raise to up position and shuts down the pump.
- 2) Reset pump, raise base bypass lever, mix guard should raise to the up position and shuts down the pump.

CATALYZER™ 2 COMPONENT SPRAY SYSTEM

CATALYZER 2K PUMP

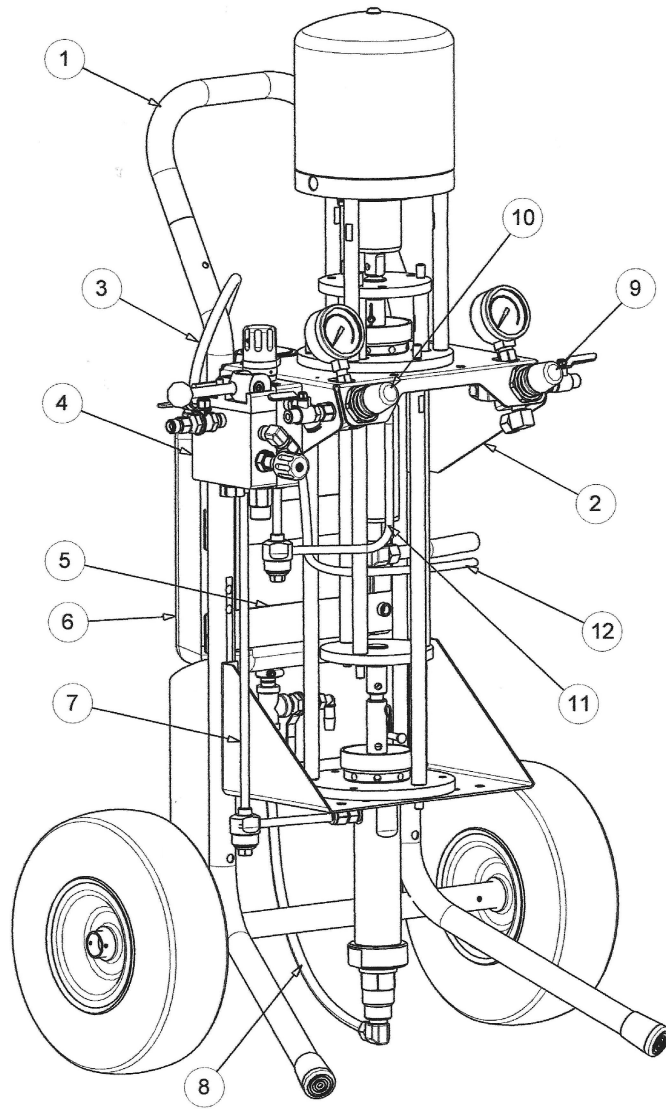

Available Tips

Std. Tip #	Opti-Tip #	Orifice Size	Fan Width*
36-207	36-207-F	0.007	4"
36-309	36-309-F	0.009	6"
36-409	36-409-F	0.009	8"
36-211	36-211-F	0.011	4"
36-311	36-311-F	0.011	6"
36-411	36-411-F	0.011	8"
36-511	36-511-F	0.011	10"
36-611	36-611-F	0.011	12"
36-213	36-213-F	0.013	4"
36-313	36-313-F	0.013	6"
36-413	36-413-F	0.013	8"
36-513	36-513-F	0.013	10"
36-613	36-613-F	0.013	12"
36-315	N/A	0.015	6"
36-415	N/A	0.015	8"
36-515	N/A	0.015	10"
36-615	N/A	0.015	12"
36-715	N/A	0.015	14"
36-815	N/A	0.015	16"
36-417	N/A	0.017	8"
36-517	N/A	0.017	10"
36-717	N/A	0.017	14"
36-619	N/A	0.019	12"
36-719	N/A	0.019	14"
36-621	N/A	0.021	12"

*Fan width is based on 10" gun to target distance. Material viscosity will influence fan width.

**Opti-Tip is proven to help reduce micro-bubbles in primers and waterborne coatings and also provides optimized atomization of topcoats, primers and paints. Opti-Tips are available for orifice sizes 0.007 thru 0.013. Order P/N 36-XXX-F Opti-Tip.

Item	Part #	Description
1	70-180	Cart Assembly
2	70-171	Pump Mounting Bracket
3	53-25-16	Catalyst Return Tube
4	70-354	Quad Valve
5	70-398	Catalyst Tank Bracket
6	51-396	Catalyst Tank Assy
7	74-311	Catalyst Discharge Tube Assy
8	74-338	Catalyst Tank to Pump Hose Assy
9	75-151	Regulator Assembly (Pump Air)
10	75-152	Regulator Assembly (Gun Air)
11	74-310	Discharge Tube Assy
12	74-552	Siphon/Return Hose Assy

CATALYZER™ 2 COMPONENT SPRAY SYSTEM

AIR MOTOR 75-100-2K

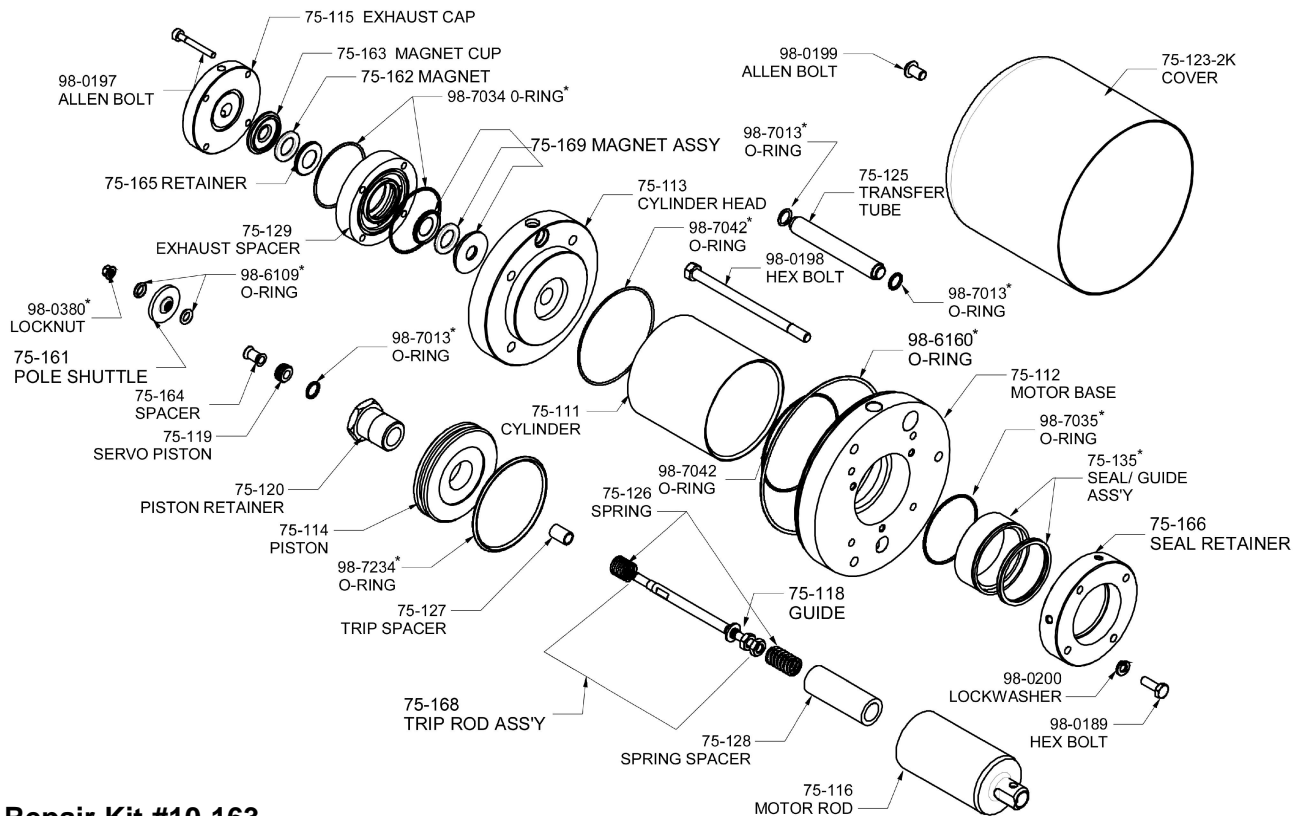

Repair Kit #10-163

Upgrade Kit #10-165 (Converts any old model pump to the new PEAK Model)

*Included in repair kit

Replacing the air motor rod seal/guide assembly

The main air motor rod seal/guide assembly can be replaced without major disassembly of air motor.

1. Push the air motor rod up as high as possible.
2. Using a 7/16" wrench, remove the three hex head bolts and remove the seal retainer plate. The exposed end of the guide has a groove. Using two screw drivers, engage the groove and pry the seal/guide assembly out.
3. Lubricate o-ring (98-7035) and the new seal/guide assembly with petroleum jelly. Insert over air motor rod and into gland cavity. **Caution! Use care not to damage seal lips.**
4. Replace the retainer plate and three retainer plate screws.

Complete air motor disassembly

It is recommended that repair kit # 10-163 be on hand before starting pump repair.

1. Remove the air motor cover using a 1/4" hex wrench.
2. Remove the four allen head bolts (98-0197).
3. Remove the exhaust cap, valve plate, and exhaust spacer.
4. Push the air motor rod to the up position. Lift up on locknut (98-0380) until a flat on the trip rod is exposed just outside the top cylinder head. Using a 1/4" open end wrench on the trip rod and a second 5/16" wrench on the locknut, remove the locknut.
5. Continue holding the trip rod and unscrew the magnet assembly. Remove the spacer and servo piston.
Note: Wrap the magnet assembly in a clean paper towel as it will attract any nearby magnetic debris.
6. Using a 1/2" wrench, remove the four hex head bolt holding retaining the cylinder head. Remove the cylinder head, cylinder and transfer tube.
7. Push the air motor rod out of the motor base. Using a 5/8" open end wrench on the air motor rod and a 1 1/4" wrench, remove the piston retainer. The trip rod and trip springs can be removed for inspection.
8. See instructions above for removal and replacement of the seal/guide assembly in the motor base.
9. Reassemble air motor in reverse order. Lubricate all o-rings using petroleum jelly during reassembly.
10. Add 1 drop of CAPlus 71TL thread locker to the trip rod assembly threads before installing magnet assembly.

CATALYZER™ 2 COMPONENT SPRAY SYSTEM

QUAD VALVE 70-354

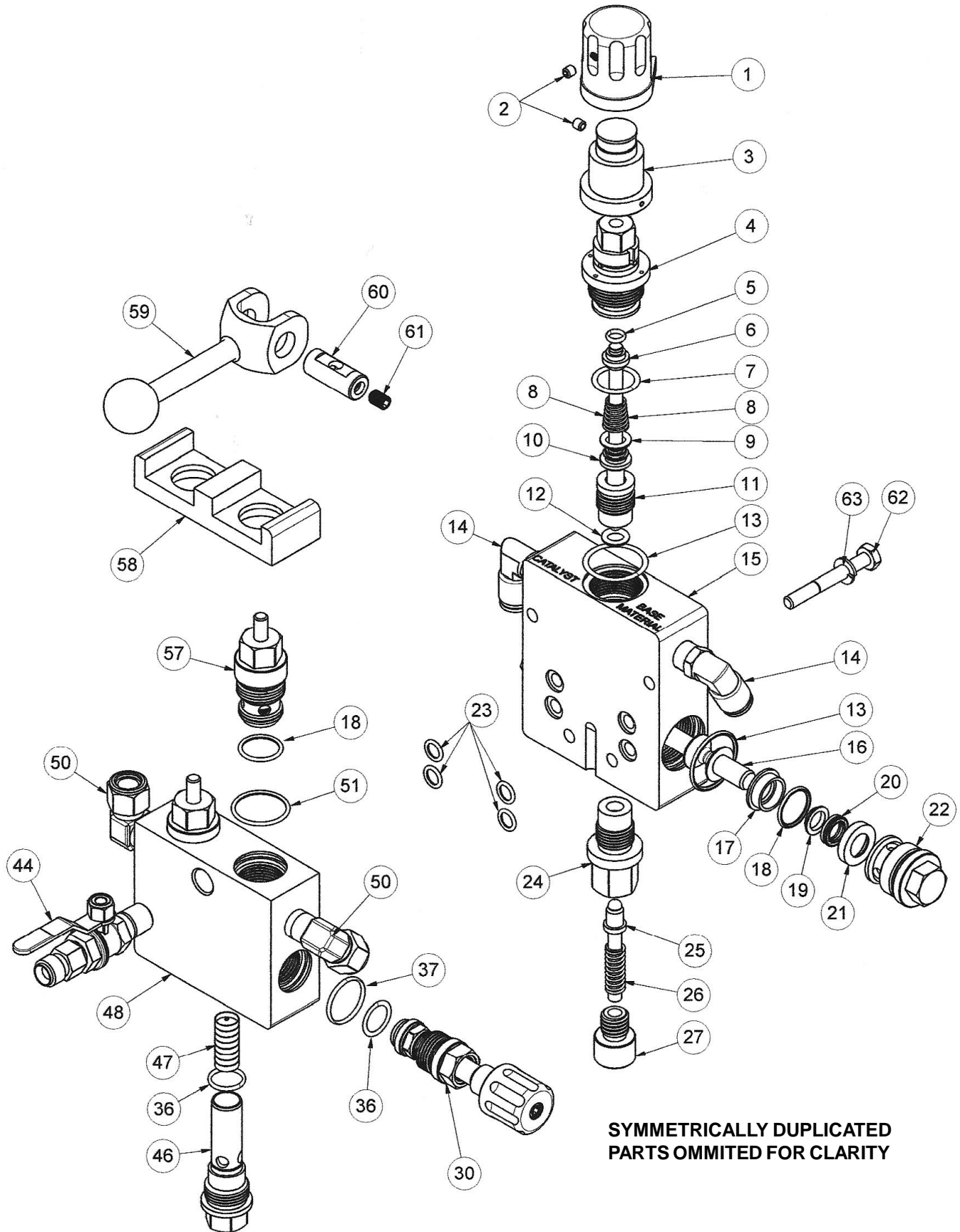

CATALYZER™ 2 COMPONENT SPRAY SYSTEM

QUAD VALVE 70-354

Item	Qty	Part #	Description
1	1	70-393	Upper Knob
2	2	98-0329	Set Screw
3	1	70-381	Lower Knob Assy
4	1	70-370	Air Valve Body Assy
5	1	98-7010	O-Ring
6	1	70-391	Spring Seat
7	1	98-7018	O-Ring
8	1	60-1325	Air Spring
9	1	98-7110	O-Ring
10	1	70-392	Air Plunger Stem
11	1	70-394	Poppet Guide
12	1	98-7109	O-Ring
13	3	98-8023	O-Ring
14	2	53-520	Elbow
15	1	70-386	MG Valve Body
16	1	70-387	Shuttle Piston
17	2	70-389	Guide Housing
18	2	98-8017	O-Ring
19	2	70-396	Piston Guide
20	2	75-228	Seal-Trip Rod
21	2	70-382	Retainer Cup
22	2	70-388	Piston Cap
23	5	98-8011	O-Ring
24	1	70-377	Centering Body
25	1	70-378	Centering Stem
26	1	70-358	Centering Spring
27	1	70-379	Centering Cap
30	2	70-372	Check Cartridge Assy
36	3	98-8015	O-Ring
37	2	98-8019	O-Ring
42	2	98-0351	Allen Screw 8-23 x 3/4
44	1	70-359	Ball Valve Assembly
46	1	70-380	Mix Tube
47	1	70-384	Mixer Element
48	1	70-356	RPC Valve Body
50	2	98-0332	Compression Fitting Elbow
51	1	98-8021	O-Ring
52	1	70-368	Seat Adapter
53	2	70-376	Stem Assy
54	2	98-8202	O-Ring
55	3	70-362	Seal Spacer
56	1	70-366	Relief Spring
57	2	70-352	Relief Valve Cartridge Assy
58	1	70-357	Dual Guide Block
59	1	70-360	R/B Lever Assy
60	1	70-369	Lever Pivot

Item	Qty	Part #	Description
61	1	98-0347	1/4-28 x 3/8 Set Screw
62	2	98-0325	1/4-20 x 2 Bolt
63	2	98-0322	AN Lock washer 1/4

CATALYZER™ 2 COMPONENT SPRAY SYSTEM

BASE PUMP 74-101-2K

Base Pump 74-101-2K

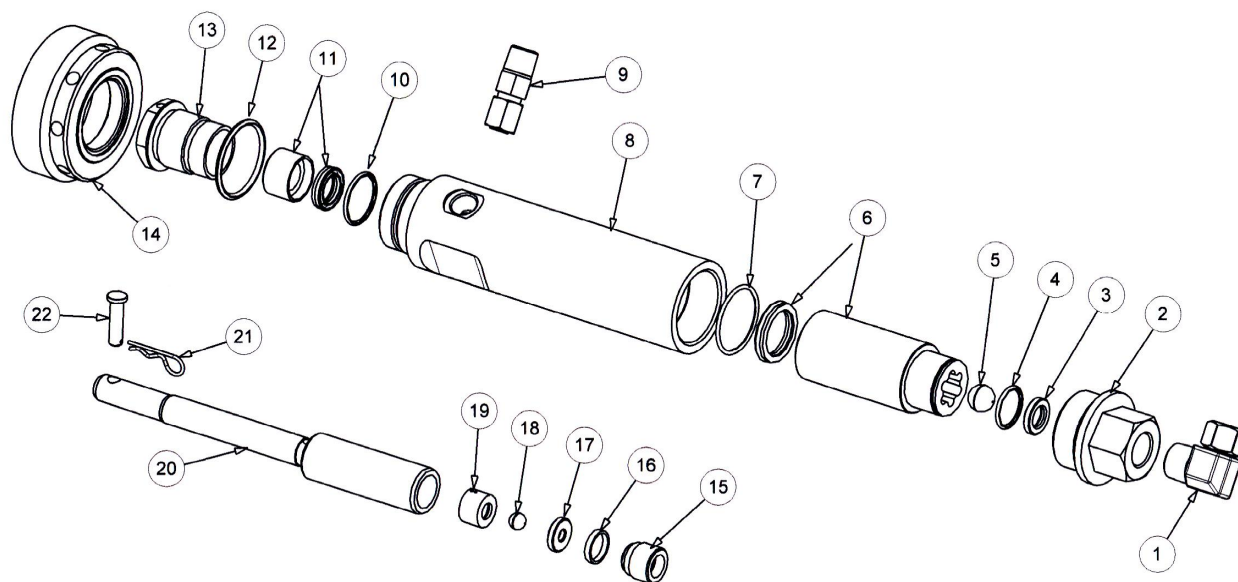

Items marked with * are included in #10-117 Repair Kit

Item	RK	Part #	Description
1		98-0344	elbow 1/2 comp x 3/8 NPT
2		74-137	inlet fitting
3		74-123	ball seat
4	*	98-8017	o-ring
5	*	98-0190	1/2" SS ball
6	*	74-130	seal/ guide ass'y
7	*	98-8025	o-ring
8		74-110	pump tube
9		98-0330	fitting- 5/16 comp x 1/4NPT
10	*	98-8020	O-RING
11	*	74-125	seal/ guide ass'y

Item	RK	Part #	Description
12	*	98-7125	O-RING
13		74-111	packing nut
14		74-127	solvent cup nut
15		74-120	seat retainer-upper
16	*	74-124	gasket-upper seat
17		74-122	ball seat
18	*	98-0191	5/16" SS ball
19		74-121	ball cage-upper ass'y
20		74-116	pump rod ass'y
21	*	98-0327	hairpin cotter
22	*	98-0203	clevis pin

CATALYZER™ 2 COMPONENT SPRAY SYSTEM

CATALYST PUMP 74-301-10

Catalyst Pump 74-301-10

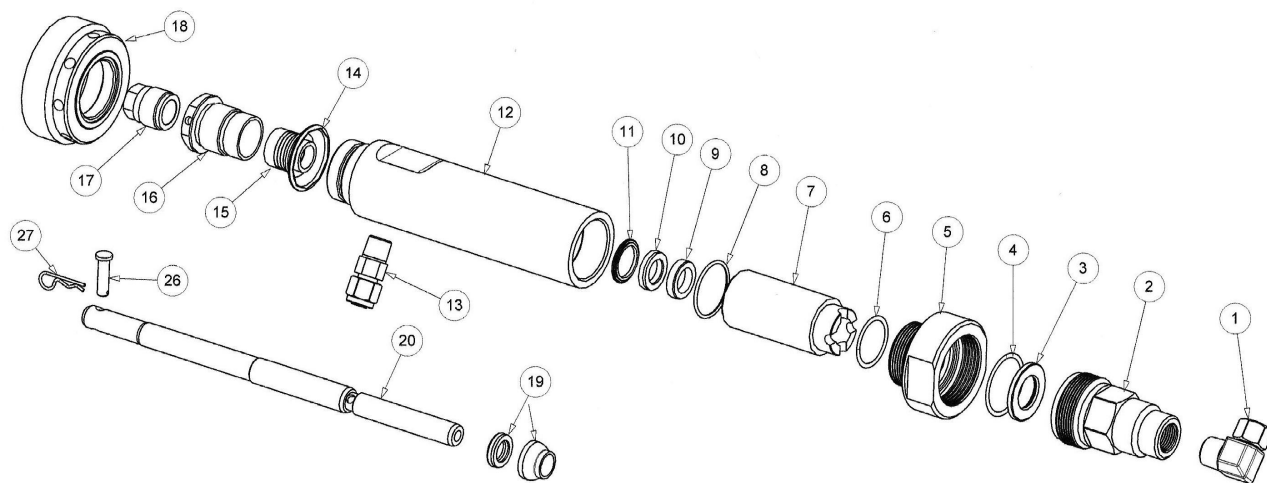

Items marked with * are included in #10-155 Repair Kit

Item	RK	Part #	Description
1		98-0333	elbow - 3/8 tube x 3/8 NPT
2		74-318	pump base
3		74-223	ball seat-low er
4	*	98-8027	o-ring
5		74-339	check adapter
6	*	98-8023	o-ring
7		74-313-10	guide low er
8	*	98-8025	o-ring
9	*	74-334	intermediate guide ring
10	*	74-315-10	seal - low er rod
11	*	74-314	seal retainer

Item	RK	Part #	Description
12		74-110	pump tube
13		98-0330	fitting - 5/16 x 1/4" NPT
14	*	98-7125	o-ring
15	*	74-135	v-pack seal set
16		74-133	v-packing nut
17		74-134	packing adjuster
18		74-127-SS	solvent cup nut
19		74-336	seal / check ball assy
20		74-326	pump rod assy
26	*	98-0203	clevis pin
27	*	98-0327	hairpin cotter

Gun Air Consumption

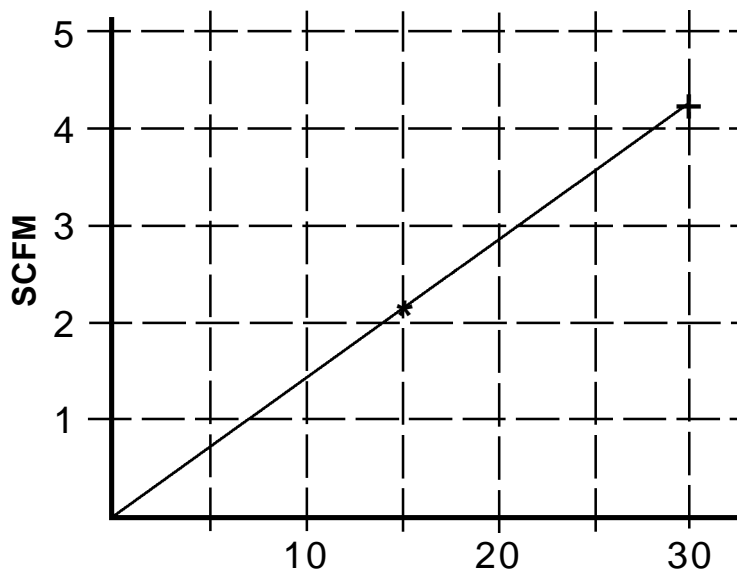

Gun Regulator Pressure - PSI

*Max pressure for HVLP

Pump Air Consumption

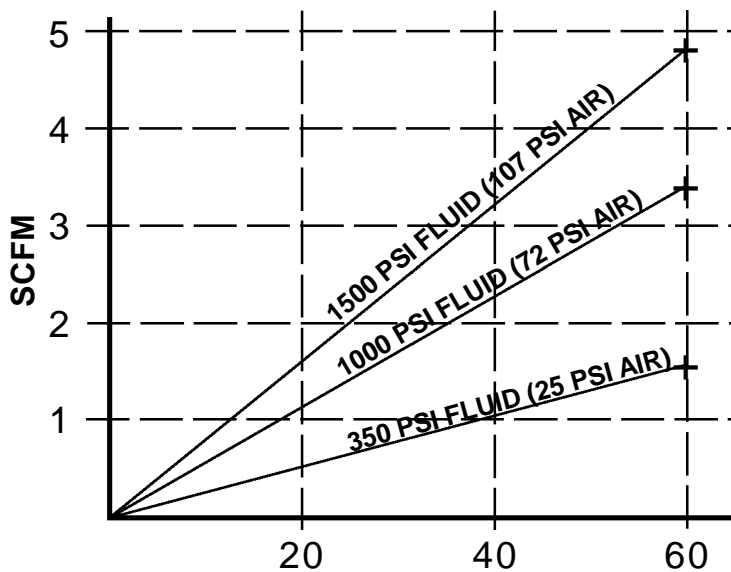

Pump Speed - Cycles per minute

13 26 39

Pump Output - Ounces per minute

Compressed Air Requirements

Minimum compressor size will vary with the application. Air requirements for the gun and pump must be added together for total air requirements.

Example: Gun Regulator Setting 25 psi, scfm = 3.5
 Pump fluid pressure is 1000 psi and cycle rate is 30, scfm = 1.75
 Minimum compressor requirement: 3.5+1.75 = 5.25 scfm



LIFETIME WARRANTY POLICY



C.A. Technologies warrants to the original purchaser that products of our manufacture are free from defects in materials and workmanship for the life of the product, excluding normal wear, when in the opinion of the company that the product has not been misused.

C.A. Technologies will at its opinion, refurbish or replace any product or part found to be defective during the warranty period. C.A. Technologies will require the purchaser to return the part(s) claimed to be defective, for its inspection, freight or postage prepaid.

This warranty does not include the cost of any inconvenience or property damage due to misuse, abuse, accident, or equipment or coating failure. This express warranty is the sole warranty given by the manufacturer and is in lieu of all other warranties, express or implied, including implied warranty of merchantability or fitness for a particular purpose. Neither distributors or retail establishments selling these products has authority to make any warranties or promise remedies in addition to or inconsistent with those stated above. C.A. Technologies maximum liability, in any event shall not exceed the purchase price of the product paid by the original purchaser. Some states do not allow the exclusion or limitation of accidental or consequential damages. So the above limitations or exclusions may not apply to you. This warranty give you specific rights and may also have other rights which may vary from state to state.